

TDA7052A/AT

1 W BTL mono audio amplifier with DC volume control

1 W BTL mono audio amplifier with DC volume control

TDA7052A/AT

FEATURES

- DC volume control
- Few external components
- Mute mode
- Thermal protection
- Short-circuit proof
- No switch-on and off clicks
- Good overall stability
- Low power consumption
- Low HF radiation
- ESD protected on all pins

GENERAL DESCRIPTION

The TDA7052A/AT are mono BTL output amplifiers with DC volume control. They are designed for use in TV and monitors, but also suitable for battery-fed portable recorders and radios.

Missing Current Limiter (MCL)

A MCL protection circuit is built-in. The MCL circuit is activated when the difference in current between the output terminal of each amplifier exceeds 100 mA (typical 300 mA). This level of 100 mA allows for headphone applications (single-ended).

QUICK REFERENCE DATA

SYMBOL	PARAMETERS	CONDITIONS	MIN.	TYP.	MAX.	UNIT
V_P	positive supply voltage range		4.5	–	18	V
P_O	output power TDA7052A TDA7052AT	$R_L = 8 \Omega$; $V_P = 6 V$ $R_L = 16 \Omega$; $V_P = 6 V$	1.0 0.5	1.1 0.55	– –	W W
G_v	maximum total voltage gain		34.5	35.5	36.5	dB
ϕ	gain control range		75	80	–	dB
I_P	total quiescent current	$V_P = 6 V$; $R_L = \infty$	–	7	12	mA
THD	total harmonic distortion TDA7052A TDA7052AT	$P_O = 0.5 W$ $P_O = 0.25 W$	– –	0.3 0.3	1 1	% %

ORDERING INFORMATION

EXTENDED TYPE NUMBER	PACKAGE			
	PINS	PIN POSITION	MATERIAL	CODE
TDA7052A	8	DIL	plastic	SOT97 ⁽¹⁾
TDA7052AT	8	mini-pack	plastic	SOT96A ⁽²⁾

Notes

1. SOT97-1; 1996 September 10.
2. SOT96-1; 1996 September 10.

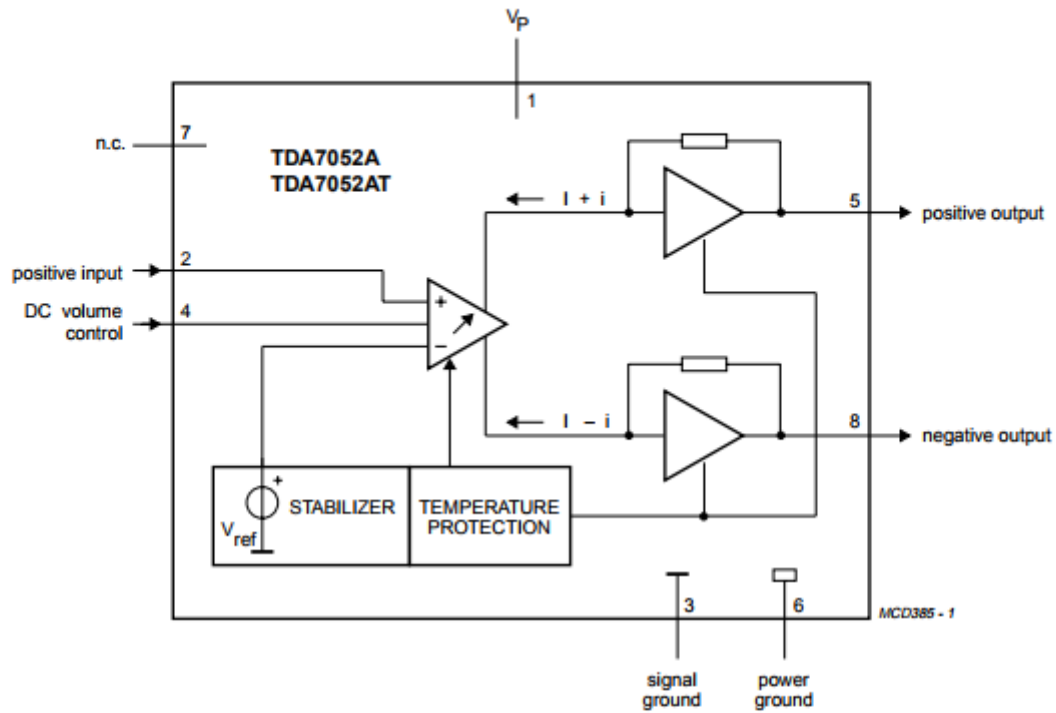

Fig.1 Block diagram.

PINNING

SYMBOL	PIN	DESCRIPTION
V_P	1	positive supply voltage
IN+	2	positive input
GND1	3	signal ground
VC	4	DC volume control
OUT+	5	positive output
GND2	6	power ground
n.c	7	not connected
OUT-	8	negative output

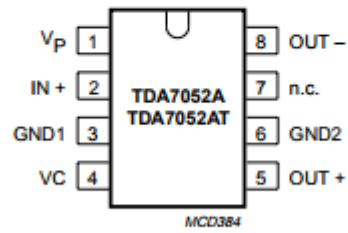

Fig.2 Pin configuration.

FUNCTIONAL DESCRIPTION

The TDA7052A/AT are mono BTL output amplifiers with DC volume control, designed for use in TV and monitors but also suitable for battery fed portable recorders and radios.

In conventional DC volume circuits the control or input stage is AC coupled to the output stage via external capacitors to keep the offset voltage low.

In the TDA7052A/AT the DC volume control stage is integrated into the input stage so that no coupling capacitors are required and yet a low offset voltage is maintained. At the same time the minimum supply remains low.

The BTL principle offers the following advantages:

- Lower peak value of the supply current
- The frequency of the ripple on the supply voltage is twice the signal frequency.

Thus a reduced power supply with smaller capacitors can be used which results in cost savings.

For portable applications there is a trend to decrease the supply voltage, resulting in a reduction of output power at conventional output stages. Using the BTL principle increases the output power.

The maximum gain of the amplifier is fixed at 35.5 dB. The DC volume control stage has a logarithmic control characteristic.

The total gain can be controlled from 35.5 dB to -44 dB. If the DC volume control voltage is below 0.3 V, the device switches to the mute mode.

The amplifier is short-circuit proof to ground, V_P and across the load. Also a thermal protection circuit is implemented. If the crystal temperature rises above +150 °C the gain will be reduced, so the output power is reduced.

Special attention is given to switch on and off clicks, low HF radiation and a good overall stability.

LIMITING VALUES

In accordance with the Absolute Maximum System (IEC 134)

SYMBOL	PARAMETER	CONDITIONS	MIN.	MAX.	UNIT
V_P	supply voltage range		-	18	V
I_{ORM}	repetitive peak output current		-	1.25	A
I_{OSM}	non-repetitive peak output current		-	1.5	A
P_{tot}	total power dissipation	$T_{amb} \leq 25\%$	-	1.25	W
	TDA7052A		-	0.8	W
T_{amb}	operating ambient temperature range		-40	+85	°C
T_{stg}	storage temperature range		-55	+150	°C
T_{vj}	virtual junction temperature		-	+150	°C
T_{sc}	short-circuit time		-	1	hr
V_2	input voltage pin 2		-	8	V
V_4	input voltage pin 4		-	8	V

THERMAL RESISTANCE

SYMBOL	PARAMETER	THERMAL RESISTANCE
$R_{th\ j-a}$	from junction to ambient in free air	
	TDA7052A	100 K/W
	TDA7052AT	155 K/W

Notes to the thermal resistance

TDA7052A: $V_P = 6\text{ V}$; $R_L = 8\ \Omega$. The maximum sine-wave dissipation is 0.9 W.
Therefore $T_{amb(max)} = 150 - 100 \times 0.9 = 60\ \text{°C}$.

TDA7052AT: $V_P = 6\text{ V}$; $R_L = 16\ \Omega$. The maximum sine-wave dissipation is 0.46 W.
Therefore $T_{amb(max)} = 150 - 155 \times 0.46 = 78\ \text{°C}$.

CHARACTERISTICS

$V_P = 6\text{ V}$; $T_{\text{amb}} = 25\text{ }^\circ\text{C}$; $f = 1\text{ kHz}$; TDA7052A: $R_L = 8\text{ }\Omega$; TDA7052AT: $R_L = 16\text{ }\Omega$; unless otherwise specified (see Fig.6).

SYMBOL	PARAMETER	CONDITIONS	MIN.	TYP.	MAX.	UNIT
V_P	positive supply voltage range		4.5	–	18	V
I_P	total quiescent current	$V_P = 6\text{ V}$; $R_L = \infty$ note 1	–	7	12	mA
Maximum gain; $V_4 = 1.4\text{ V}$						
P_O	output power TDA7052A TDA7052AT	THD = 10%	1.0 0.5	1.1 0.55	– –	W W
THD	total harmonic distortion TDA7052A TDA7052AT	$P_O = 0.5\text{ W}$ $P_O = 0.25\text{ W}$	– –	0.3 0.3	1 1	% %
G_V	voltage gain		34.5	35.5	36.5	dB
V_I	input signal handling	$V_4 = 0.8\text{ V}$; THD < 1%	0.5	0.65	–	V
$V_{\text{no(rms)}}$	noise output voltage (RMS value)	$f = 500\text{ kHz}$; note 2	–	210	–	μV
B	bandwidth	–1 dB	–	20 Hz to 300 kHz	–	
SVRR	supply voltage ripple rejection	note 3	38	46	–	dB
$ V_{\text{off}} $	DC output offset voltage		–	0	150	mV
Z_I	input impedance (pin 2)		15	20	25	k Ω
Minimum gain; $V_4 = 0.5\text{ V}$						
G_V	voltage gain		–	–44	–	dB
$V_{\text{no(rms)}}$	noise output voltage (RMS value)	note 4	–	20	30	μV
Mute position						
V_O	output voltage in mute position	$V_4 \leq 0.3\text{ V}$; $V_I = 600\text{ mV}$	–	–	30	μV
DC volume control						
ϕ	gain control range		75	80	–	dB
I_4	control current	$V_4 = 0.4\text{ V}$	60	70	80	μA

Notes to the characteristics

1. With a load connected to the outputs the quiescent current will increase, the maximum value of this increase being equal to the DC output offset voltage dividend by R_L .
2. The noise output voltage (RMS value) at $f = 500\text{ kHz}$ is measured with $R_S = 0\text{ }\Omega$ and bandwidth = 5 kHz.
3. The ripple rejection is measured with $R_S = 0\text{ }\Omega$ and $f = 100\text{ Hz}$ to 10 kHz. The ripple voltage of 200 mV, (RMS value) is applied to the positive supply rail.
4. The noise output voltage (RMS value) is measured with $R_S = 5\text{ k}\Omega$ unweighted.

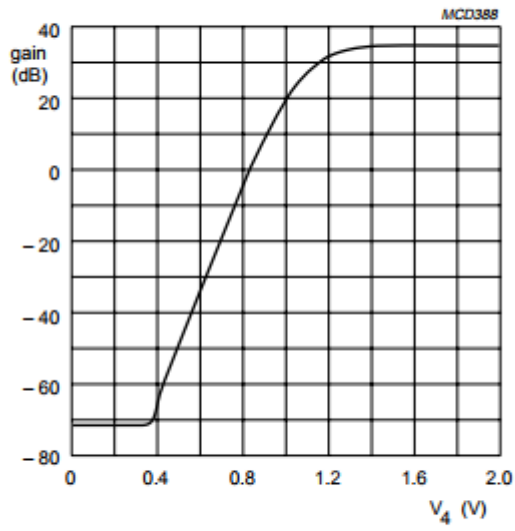

Fig.3 Gain control as a function of DC volume control.

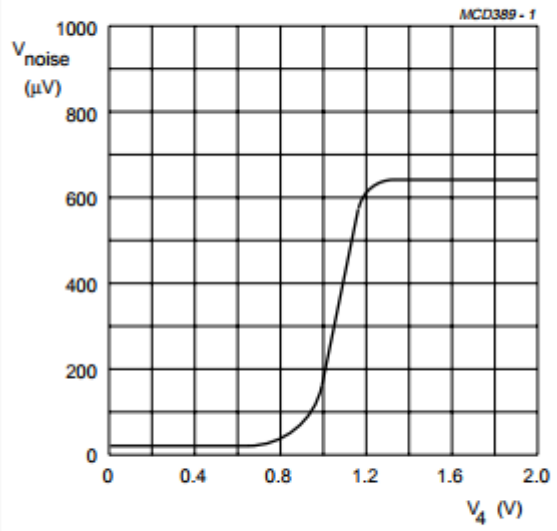

Fig.4 Noise output voltage as a function of DC volume control.

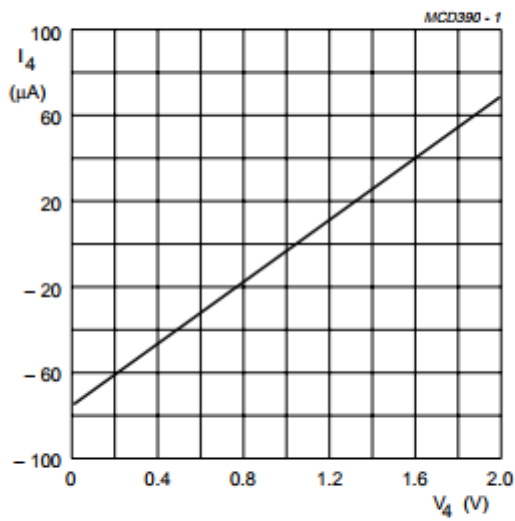

Fig.5 Control current as a function of DC volume control.

APPLICATION INFORMATION

