

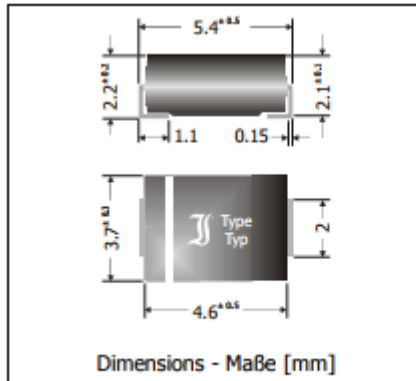

S2A ... S2Y

Surface Mount Silicon Rectifier Diodes Silizium-Gleichrichterdioden für die Oberflächenmontage

Version 2012-04-04



Nominal Current – Nennstrom	2 A
Reverse voltage – Sperrspannung	50...2000 V
Plastic case Kunststoffgehäuse	~ SMB ~ DO-214AA
Weight approx. – Gewicht ca.	0.1 g
Plastic material has UL classification 94V-0 Gehäusematerial UL94V-0 klassifiziert	
Standard packaging taped and reeled Standard Lieferform gegurtet auf Rolle	

Maximum ratings and characteristics

Grenz- und Kennwerte

Type Typ	Repetitive peak reverse voltage Periodische Spitzensperrspannung V_{RRM} [V]	Surge peak reverse voltage Stoßspitzensperrspannung V_{RSM} [V]
S2A	50	50
S2B	100	100
S2D	200	200
S2G	400	400
S2J	600	600
S2K	800	800
S2M	1000	1000
S2T	1300	1300
S2W	1600	1600
S2X	1800	1800
S2Y	2000	2000

Max. average forw. rectified current – Dauergrenzstr. in Einwegschaltung	$T_T = 100^\circ\text{C}$	I_{FAV}	2 A ¹⁾
Repetitive peak forward current – Periodischer Spitzenstrom	$f > 15\text{ Hz}$	I_{FRM}	10 A ²⁾
Surge current, 50/60 Hz half sine – Stoßstrom 50/60 Hz Sinus-Halbwellen	$T_A = 25^\circ\text{C}$	I_{FSM}	50/55 A
Rating for fusing, $t < 10\text{ ms}$ – Grenzlastintegral, $t < 10\text{ ms}$	$T_A = 25^\circ\text{C}$	i^2t	12 A ² s
Junction temperature – Sperrschichttemperatur		T_j	-50...+150°C
Storage temperature – Lagerungstemperatur		T_s	-50...+150°C
Forward voltage – Durchlass-Spannung	$T_j = 25^\circ\text{C}$ $I_F = 2\text{ A}$	V_F	< 1.15 V
Leakage current	$T_j = 25^\circ\text{C}$ $V_R = V_{RRM}$	I_R	< 5 μA
Sperrstrom	$T_j = 100^\circ\text{C}$ $V_R = V_{RRM}$	I_R	< 100 μA
Thermal resistance junction to ambient – Wärmewiderstand Sperrschicht-Umgebung		R_{thA}	< 50 K/W ²⁾
Thermal resistance junction-terminal – Wärmewiderstand Sperrschicht-Anschluss		R_{thT}	< 15 K/W

1 R-load – R-Last

2 Mounted on P.C. board with 50 mm² copper pads at each terminal
Montage auf Leiterplatte mit 50 mm² Kupferbelag (Löt-pad) an jedem Anschluss

