



## Features

- Fast Read Access Time – 70 ns
- 5-volt Only Reprogramming
- Sector Program Operation
  - Single Cycle Reprogram (Erase and Program)
  - 1024 Sectors (256 Bytes/Sector)
  - Internal Address and Data Latches for 256 Bytes
- Internal Program Control and Timer
- Hardware and Software Data Protection
- Two 8K Bytes Boot Blocks with Lockout
- Fast Sector Program Cycle Time – 10 ms
- DATA Polling for End of Program Detection
- Low Power Dissipation
  - 40 mA Active Current
  - 100  $\mu$ A CMOS Standby Current
- Typical Endurance > 10,000 Cycles
- Single 5V  $\pm$ 10% Supply
- CMOS and TTL Compatible Inputs and Outputs
- Commercial and Industrial Temperature Ranges

## Description

The AT29C020 is a 5-volt-only in-system Flash programmable and erasable read-only memory (PEROM). Its 2 megabits of memory is organized as 262,144 bytes. Manufactured with Atmel's advanced nonvolatile CMOS technology, the device offers access times to 70 ns with power dissipation of just 220 mW over the commercial temperature range. When the device is deselected, the CMOS standby current is less than 100  $\mu$ A. Device endurance is such that any sector can typically be written to in excess of 10,000 times.

## Pin Configurations

Pin Name	Function
A0 - A17	Addresses
$\overline{CE}$	Chip Enable
$\overline{OE}$	Output Enable
$\overline{WE}$	Write Enable
I/O0 - I/O7	Data Inputs/Outputs
NC	No Connect

DIP Top View



PLCC Top View

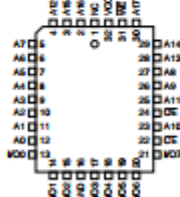

TSOP Top View Type 1

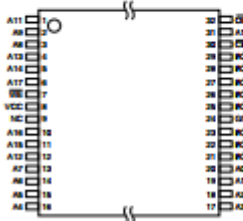

## 2-megabit (256K x 8) 5-volt Only Flash Memory

## AT29C020

## Block Diagram

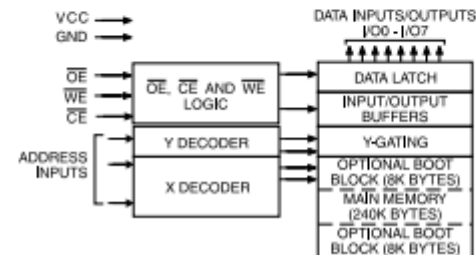

## Device Operation

To allow for simple in-system reprogrammability, the AT29C020 does not require high input voltages for programming. Five-volt-only commands determine the operation of the device. Reading data out of the device is similar to reading from an EPROM. Reprogramming the AT29C020 is performed on a sector basis; 256 bytes of data are loaded into the device and then simultaneously programmed.

During a reprogram cycle, the address locations and 256 bytes of data are internally latched, freeing the address and data bus for other operations. Following the initiation of a program cycle, the device will automatically erase the sector and then program the latched data using an internal control timer. The end of a program cycle can be detected by DATA polling of I/O7. Once the end of a program cycle has been detected, a new access for a read or program can begin.

**READ:** The AT29C020 is accessed like an EPROM. When  $\overline{CE}$  and  $\overline{OE}$  are low and  $\overline{WE}$  is high, the data stored at the memory location determined by the address pins is asserted on the outputs. The outputs are put in the high impedance state whenever  $\overline{CE}$  or  $\overline{OE}$  is high. This dual-line control gives designers flexibility in preventing bus contention.

**BYTE LOAD:** Byte loads are used to enter the 256 bytes of a sector to be programmed or the software codes for data protection. A byte load is performed by applying a low pulse on the  $\overline{WE}$  or  $\overline{CE}$  input with  $\overline{CE}$  or  $\overline{WE}$  low (respectively) and  $\overline{OE}$  high. The address is latched on the falling edge of  $\overline{CE}$  or  $\overline{WE}$ , whichever occurs last. The data is latched by the first rising edge of  $\overline{CE}$  or  $\overline{WE}$ .

**PROGRAM:** The device is reprogrammed on a sector basis. If a byte of data within a sector is to be changed, data for the entire sector must be loaded into the device. Any byte that is not loaded during the programming of its sector will be indeterminate. Once the bytes of a sector are loaded into the device, they are simultaneously programmed during the internal programming period. After the first data byte has been loaded into the device, successive bytes are entered in the same manner. Each new byte to be programmed must have its high-to-low transition on  $\overline{WE}$  (or  $\overline{CE}$ ) within 150  $\mu$ s of the low-to-high transition of  $\overline{WE}$  (or  $\overline{CE}$ ) of the preceding byte. If a high-to-low transition is not detected within 150  $\mu$ s of the last low-to-high transition, the load period will end and the internal programming period will start. A8 to A17 specify the sector address. The sector address must be valid during each high-to-low transition of  $\overline{WE}$  (or  $\overline{CE}$ ). A0 to A7 specify the byte address within the sector. The bytes may be loaded in any order; sequential loading is not required. Once a programming operation has been initiated, and for the duration of  $t_{WC}$ , a read operation will effectively be a polling operation.

Rev. 0291N-FLASH-07/02





**SOFTWARE DATA PROTECTION:** A software controlled data protection feature is available on the AT29C020. Once the software protection is enabled a software algorithm must be issued to the device before a program may be performed. The software protection feature may be enabled or disabled by the user; when shipped from Atmel, the software data protection feature is disabled. To enable the software data protection, a series of three program commands to specific addresses with specific data must be performed. After the software data protection is enabled the same three program commands must begin each program cycle in order for the programs to occur. All software program commands must obey the sector program timing specifications. Once set, the software data protection feature remains active unless its disable command is issued. Power transitions will not reset the software data protection feature; however, the software feature will guard against inadvertent program cycles during power transitions.

After setting SDP, any attempt to write to the device without the 3-byte command sequence will start the internal write timers. No data will be written to the device; however, for the duration of  $t_{WC}$ , a read operation will effectively be a polling operation.

After the software data protection's 3-byte command code is given, a sector of data is loaded into the device using the sector program timing specifications.

**HARDWARE DATA PROTECTION:** Hardware features protect against inadvertent programs to the AT29C020 in the following ways: (a)  $V_{CC}$  sense – if  $V_{CC}$  is below 3.8V (typical), the program function is inhibited; (b)  $V_{CC}$  power on delay – once  $V_{CC}$  has reached the  $V_{CC}$  sense level, the device will automatically time out 5 ms (typical) before programming; (c) Program inhibit – holding any one of  $\overline{OE}$  low,  $\overline{CE}$  high or  $\overline{WE}$  high inhibits program cycles; and (d) Noise filter – pulses of less than 15 ns (typical) on the  $\overline{WE}$  or  $\overline{CE}$  inputs will not initiate a program cycle.

**PRODUCT IDENTIFICATION:** The product identification mode identifies the device and manufacturer as Atmel. It may be accessed by hardware or software operation. The hardware operation mode can be used by an external programmer to identify the correct programming algorithm for the Atmel product. In addition, users may wish to use the software product identification mode to identify the part (i.e. using the device code), and have the system software use the appropriate sector size for program operations. In this manner, the user can have a common board design for 256K to 4-megabit densities and, with each density's sector size in a memory map, have the system software apply the appropriate sector size.

For details, see Operating Modes (for hardware operation) or Software Product Identification. The manufacturer and device code is the same for both modes.

**DATA POLLING:** The AT29C020 features  $\overline{DATA}$  polling to indicate the end of a program cycle. During a program cycle an attempted read of the last byte loaded will result in the complement of the loaded data on I/O7. Once the program cycle has been completed, true data is valid on all outputs and the next cycle may begin.  $\overline{DATA}$  polling may begin at any time during the program cycle.

**TOGGLE BIT:** In addition to  $\overline{DATA}$  polling the AT29C020 provides another method for determining the end of a program or erase cycle. During a program or erase operation, successive attempts to read data from the device will result in I/O6 toggling between one and zero. Once the program cycle has completed, I/O6 will stop toggling and valid data will be read. Examining the toggle bit may begin at any time during a program cycle.

**OPTIONAL CHIP ERASE MODE:** The entire device can be erased by using a 6-byte software code. Please see Software Chip Erase application note for details.

**BOOT BLOCK PROGRAMMING LOCKOUT:** The AT29C020 has two designated memory blocks that have a programming lockout feature. This feature prevents programming of data in the designated block once the feature has been enabled. Each of these blocks consists of 8K bytes; the programming lockout feature can be set independently for either block. While the lockout feature does not have to be activated, it can be activated for either or both blocks.

These two 8K memory sections are referred to as *boot blocks*. Secure code which will bring up a system can be contained in a boot block. The AT29C020 blocks are located in the first 8K bytes of memory and the last 8K bytes of memory. The boot block programming lockout feature can therefore support systems that boot from the lower addresses of memory or the higher addresses. Once the programming lockout feature has been activated, the data in that block can no longer be erased or programmed; data in other memory locations can still be changed through the regular programming methods. To activate the lockout feature, a series of seven program commands to specific addresses with specific data must be performed. Please see Boot Block Lockout Feature Enable Algorithm.

If the boot block lockout feature has been activated on either block, the chip erase function will be disabled.

**BOOT BLOCK LOCKOUT DETECTION:** A software method is available to determine whether programming of either boot block section is locked out. See Software Product Identification Entry and Exit sections. When the device is in the software product identification mode, a read from location 00002H will show if programming the lower address boot block is locked out while reading location 3FFF2H will do so for the upper boot block. If the data is FE, the corresponding block can be programmed; if the data is FF, the program lockout feature has been activated and the corresponding block cannot be programmed. The software product identification exit mode should be used to return to standard operation.

**Absolute Maximum Ratings\***

Temperature Under Bias .....	-55°C to +125°C
Storage Temperature .....	-65°C to +150°C
All Input Voltages (including NC Pins) with Respect to Ground .....	-0.6V to +6.25V
All Output Voltages with Respect to Ground .....	-0.6V to $V_{CC} + 0.6V$
Voltage on $\overline{OE}$ with Respect to Ground .....	-0.6V to +13.5V

\*NOTICE: Stresses beyond those listed under "Absolute Maximum Ratings" may cause permanent damage to the device. This is a stress rating only and functional operation of the device at these or any other conditions beyond those indicated in the operational sections of this specification is not implied. Exposure to absolute maximum rating conditions for extended periods may affect device reliability.





DC and AC Operating Range

		AT29C020-70	AT29C020-90	AT29C020-10	AT29C020-12	AT29C020-15
Operating Temperature (Case)	Com.	0°C - 70°C	0°C - 70°C	0°C - 70°C	0°C - 70°C	0°C - 70°C
	Ind.	-40°C - 85°C	-40°C - 85°C	-40°C - 85°C	-40°C - 85°C	-40°C - 85°C
V <sub>CC</sub> Power Supply		5V ± 10%	5V ± 10%	5V ± 10%	5V ± 10%	5V ± 10%

Note:  Not recommended for New Designs.

Operating Modes

Mode	CE	OE	WE	AI	I/O
Read	V <sub>IL</sub>	V <sub>L</sub>	V <sub>BI</sub>	Ai	D <sub>OUT</sub>
Program <sup>(1)</sup>	V <sub>IL</sub>	V <sub>BI</sub>	V <sub>IL</sub>	Ai	D <sub>IN</sub>
5V Chip Erase	V <sub>IL</sub>	V <sub>BI</sub>	V <sub>IL</sub>	Ai	
Standby/Write Inhibit	V <sub>BI</sub>	X <sup>(1)</sup>	X	X	High Z
Program Inhibit	X	X	V <sub>BI</sub>		
Program Inhibit	X	V <sub>L</sub>	X		
Output Disable	X	V <sub>BI</sub>	X		High Z
Product Identification					
Hardware	V <sub>IL</sub>	V <sub>L</sub>	V <sub>BI</sub>	A1 - A17 = V <sub>IL</sub> , A9 = V <sub>BI</sub> <sup>(2)</sup> , A0 = V <sub>L</sub>	Manufacturer Code <sup>(4)</sup>
				A1 - A17 = V <sub>L</sub> , A9 = V <sub>BI</sub> , A0 = V <sub>BI</sub>	Device Code <sup>(4)</sup>
Software <sup>(3)</sup>				A0 = V <sub>IL</sub>	Manufacturer Code <sup>(4)</sup>
				A0 = V <sub>BI</sub>	Device Code <sup>(4)</sup>

- Notes:
- X can be V<sub>L</sub> or V<sub>BI</sub>.
  - Refer to AC Programming Waveforms.
  - V<sub>BI</sub> = 12.0V ± 0.5V.
  - Manufacturer Code: 1F, Device Code: DA.
  - See details under Software Product Identification Entry/Exit.

DC Characteristics

Symbol	Parameter	Condition	Min	Max	Units
I <sub>LI</sub>	Input Load Current	V <sub>BI</sub> = 0V to V <sub>CC</sub>		10	µA
I <sub>LO</sub>	Output Leakage Current	V <sub>IO</sub> = 0V to V <sub>CC</sub>		10	µA
I <sub>SB1</sub>	V <sub>CC</sub> Standby Current CMOS	CE = V <sub>CC</sub> - 0.3V to V <sub>CC</sub>	Com.	100	µA
			Ind.	300	µA
I <sub>SB2</sub>	V <sub>CC</sub> Standby Current TTL	CE = 2.0V to V <sub>CC</sub>		3	mA
I <sub>CC</sub>	V <sub>CC</sub> Active Current	f = 5 MHz; I <sub>OUT</sub> = 0 mA		40	mA
V <sub>IL</sub>	Input Low Voltage			0.8	V
V <sub>BI</sub>	Input High Voltage		2.0		V
V <sub>OL</sub>	Output Low Voltage	I <sub>OL</sub> = 2.1 mA		0.45	V
V <sub>OHI</sub>	Output High Voltage	I <sub>OHI</sub> = -400 µA	2.4		V
V <sub>OHI2</sub>	Output High Voltage CMOS	I <sub>OHI</sub> = -100 µA; V <sub>CC</sub> = 4.5V	4.2		V



AC Read Characteristics

Symbol	Parameter	AT29C020-90		AT29C020-90		AT29C020-10		AT29C020-12		AT29C020-15		Units
		Min	Max	Min	Max	Min	Max	Min	Max	Min	Max	
t <sub>ACC</sub>	Address to Output Delay	0	70	0	90		100		120		150	ns
t <sub>CE</sub> <sup>(1)</sup>	CE to Output Delay		70		90		100		120		150	ns
t <sub>OE</sub> <sup>(2)</sup>	OE to Output Delay	0	40	0	40	0	50	0	50	0	70	ns
t <sub>DF</sub> <sup>(3)(4)</sup>	CE or OE to Output Float	0	25	0	25	0	25	0	30	0	40	ns
t <sub>OH</sub>	Output Hold from OE, CE or Address, whichever occurred first	0		0		0		0		0		ns

Note:  Not recommended for New Designs.

AC Read Waveforms<sup>(1)(2)(3)(4)</sup>

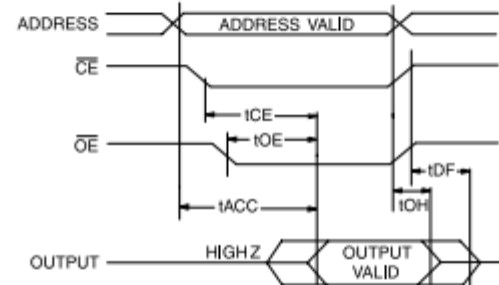

- Notes:
- CE may be delayed up to t<sub>ACC</sub> - t<sub>CE</sub> after the address transition without impact on t<sub>ACC</sub>.
  - OE may be delayed up to t<sub>CE</sub> - t<sub>OE</sub> after the falling edge of CE without impact on t<sub>CE</sub> or by t<sub>ACC</sub> - t<sub>OE</sub> after an address change without impact on t<sub>ACC</sub>.
  - t<sub>DF</sub> is specified from OE or CE whichever occurs first (CL = 5 pF).
  - This parameter is characterized and is not 100% tested.





Input Test Waveforms and Measurement Level

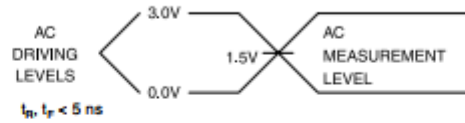

Output Test Load

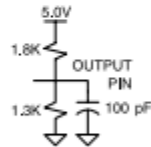

Pin Capacitance

f = 1 MHz, T = 25°C<sup>(1)</sup>

Symbol	Typ	Max	Units	Conditions
C <sub>IN</sub>	4	6	pF	V <sub>IN</sub> = 0V
C <sub>OUT</sub>	8	12	pF	V <sub>OUT</sub> = 0V

Note: 1. This parameter is characterized and is not 100% tested.

AC Byte Load Characteristics

Symbol	Parameter	Min	Max	Units
t <sub>AS-IOES</sub>	Address, $\overline{OE}$ Set-up Time	0		ns
t <sub>AH</sub>	Address Hold Time	50		ns
t <sub>CS</sub>	Chip Select Set-up Time	0		ns
t <sub>CH</sub>	Chip Select Hold Time	0		ns
t <sub>WPH</sub>	Write Pulse Width ( $\overline{WE}$ or $\overline{CE}$ )	90		ns
t <sub>DS</sub>	Data Set-up Time	50		ns
t <sub>DH-IOEH</sub>	Data, $\overline{OE}$ Hold Time	0		ns
t <sub>WPH</sub>	Write Pulse Width High	100		ns

AC Byte Load Waveforms

$\overline{WE}$  Controlled

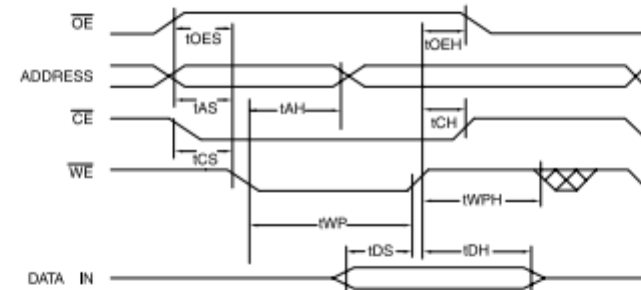

$\overline{CE}$  Controlled

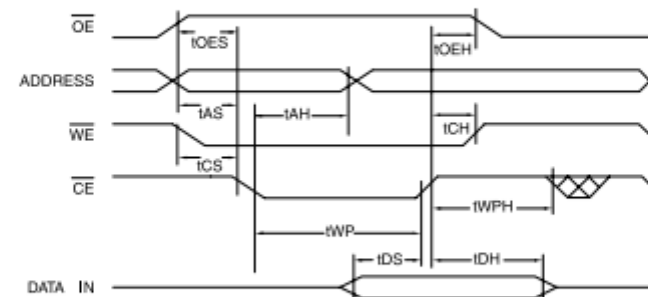



Program Cycle Characteristics

Symbol	Parameter	Min	Max	Units
$t_{WC}$	Write Cycle Time		10	ms
$t_{AS}$	Address Set-up Time	0		ns
$t_{AH}$	Address Hold Time	50		ns
$t_{DS}$	Data Set-up Time	50		ns
$t_{DH}$	Data Hold Time	0		ns
$t_{WP}$	Write Pulse Width	90		ns
$t_{BLC}$	Byte Load Cycle Time		150	$\mu$ s
$t_{WPH}$	Write Pulse Width High	100		ns

Program Cycle Waveforms<sup>(1)(2)(3)</sup>

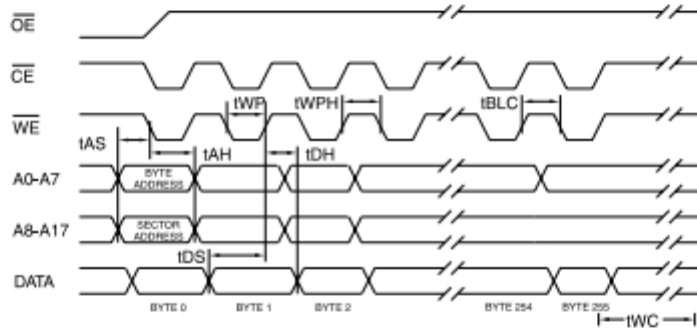

- Notes: 1. A8 through A17 must specify the sector address during each high-to-low transition of WE (or CE).
- 2. OE must be high when WE and CE are both low.
- 3. All words that are not loaded within the sector being programmed will be indeterminate.

Software Data Protection Enable Algorithm<sup>(1)</sup>

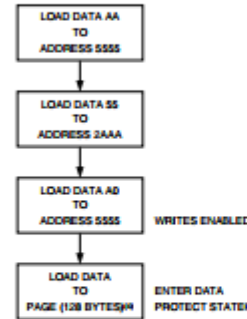

Software Data Protection Disable Algorithm<sup>(1)</sup>

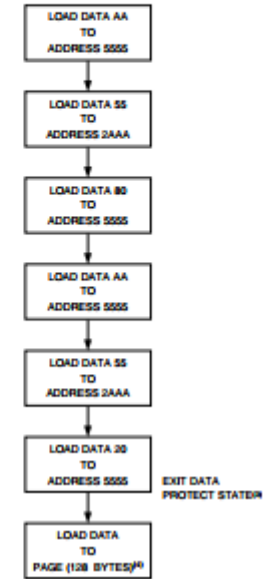

- Notes: 1. Data Format: I/O7 - I/O0 (Hex); Address Format: A14 - A0 (Hex).
- 2. Data Protect state will be activated at end of program cycle.
- 3. Data Protect state will be deactivated at end of program period.
- 4. 256 bytes of data MUST BE loaded.

Software Protected Program Cycle Waveform<sup>(1)(4)(5)</sup>

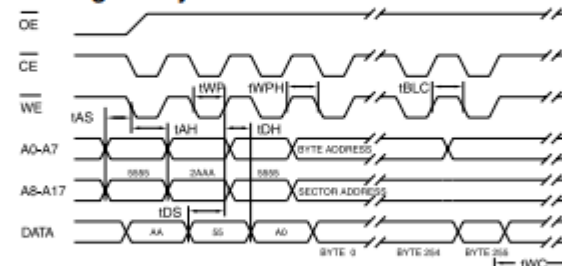

- Notes: 1. A8 through A17 must specify the sector address during each high-to-low transition of WE (or CE) after the software code has been entered.
- 4. OE must be high when WE and CE are both low.
- 5. All bytes that are not loaded within the sector being programmed will be indeterminate.



Data Polling Characteristics<sup>(1)</sup>

Symbol	Parameter	Min	Typ	Max	Units
t <sub>DH</sub>	Data Hold Time	10			ns
t <sub>OEH</sub>	OE Hold Time	10			ns
t <sub>OE</sub>	OE to Output Delay <sup>(2)</sup>				ns
t <sub>WR</sub>	Write Recovery Time	0			ns

Notes: 1. These parameters are characterized and not 100% tested.  
2. See t<sub>OE</sub> spec in AC Read Characteristics.

Data Polling Waveforms

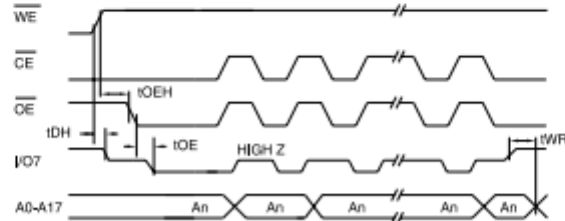

Toggle Bit Characteristics<sup>(1)</sup>

Symbol	Parameter	Min	Typ	Max	Units
t <sub>DH</sub>	Data Hold Time	10			ns
t <sub>OEH</sub>	OE Hold Time	10			ns
t <sub>OE</sub>	OE to Output Delay <sup>(2)</sup>				ns
t <sub>OEHP</sub>	OE High Pulse	150			ns
t <sub>WR</sub>	Write Recovery Time	0			ns

Notes: 1. These parameters are characterized and not 100% tested.  
2. See t<sub>OE</sub> spec in AC Read Characteristics.

Toggle Bit Waveforms<sup>(1)(2)(3)</sup>

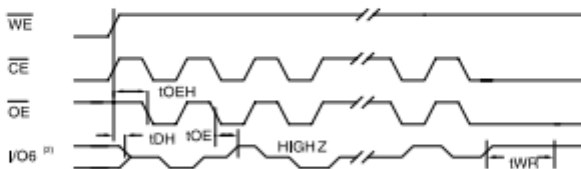

Notes: 1. Toggling either OE or CE or both OE and CE will operate toggle bit.  
2. Beginning and ending state of IO6 may vary.  
3. Any address location may be used but the address should not vary.

Software Product Identification Entry<sup>(1)</sup>

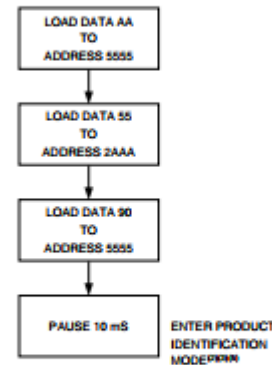

Software Product Identification Exit<sup>(1)</sup>

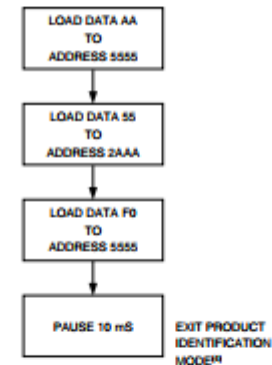

Notes: 1. Data Format: I/O15 - I/O0 (Hex); Address Format: A14 - A0 (Hex).  
2. A1 - A17 = V<sub>IL</sub>. Manufacturer Code is read for A0 = V<sub>IL</sub>; Device Code is read for A0 = V<sub>IP</sub>.  
3. The device does not remain in identification mode if powered down.  
4. The device returns to standard operation mode.  
5. Manufacturer Code is 1F. The Device Code is DA.

Boot Block Lockout Feature Enable Algorithm<sup>(1)</sup>

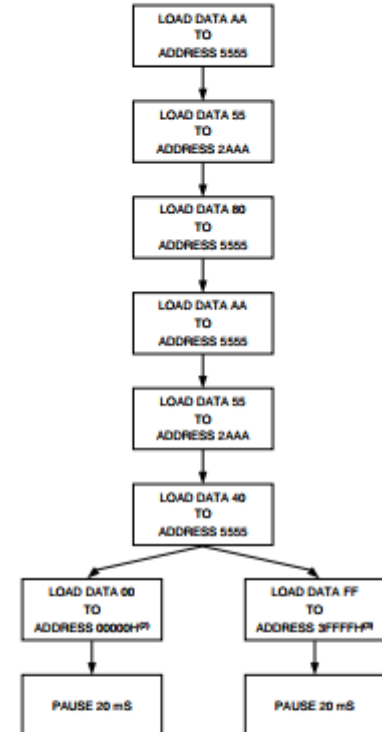

Notes: 1. Data Format: I/O7 - I/O0 (Hex); Address Format: A14 - A0 (Hex).  
2. Lockout feature set on lower address boot block.  
3. Lockout feature set on higher address boot block.



